



PRODUCT SPECIFICATION

MODEL: PV013004AR24E

< ◆ > PRELIMINARY SPECIFICATION

< ◇ > APPROVAL SPECIFICATION

CUSTOMER
APPROVED BY
DATE:

DESIGNED	CHECKED	APPROVED



Add: 2nd Floor, Building C, Jia Huang Yuan Technical Park, Tiegang, Xixiang, Bao'an District, Shenzhen city, Guangdong province, P.R.China 518126.

E-mail: Helen@kingtechgroup.cn TEL: 86-755- 23037763 Mobile: +86-139-2528-0716 Web: www.kingtechgroup.cn

<u>REV NO</u>	<u>REV DATE</u>	<u>PAGE</u>	<u>CONTENTS</u>	<u>ISSUER</u>
1.0	2019-01-08	18	First Release	LiBingbing
1.1	2019-03-19	18	按客户要求，修改尺寸标注公差	LiBingbing



TABLE OF CONTENT

- GENERAL SPECIFICATIONS
- ABSOLUTE MAXIMUM RATINGS
- ELECTRICAL CHARACTERISTICS
- DIMENSIONAL DRAWING
- INTERFACE PIN CONNECTIONS
- TIMING CHARACTERISTICS OF INPUT SIGNAL
- ELECTRO-OPTICAL CHARACTERISTICS
- RELIABILITY
- INSPECTION CRITERIA
- HANDLING PRECAUTION



1.0 GENERAL SPECIFICATIONS

PV013004AR24E is a color active matrix LCD module incorporating amorphous silicon TFT (Thin Film Transistor). It is composed of a color TFT-LCD panel, driver IC, FPC and a backlight unit. The module display area contains 240 * 240 pixels. This product accords with RoHS environmental criterion.

Item	Contents	Unit
Screen Diagonal	1.3"	Inch
Viewing direction	Full View	
Number of Dots	240(RGB) * 240	/
Display Mode	Normally Black	/
Number of color	262K	/
outline dimension	26.16 * 29.22 * 1.60	mm
Dot pitch	0.0975(W) * 0.0975(H)	mm
Active area	23.40(W) * 23.40(H)	mm
Interface	8bit parallel & SPI	
LCM Luminance	330(min)	cd/m ²
Response Time (Tr+Tf)	25ms (typ)	/



2.0 ABSOLUTE MAXIMUM RATINGS

The following are maximum values which if exceeded may cause faulty operation or damage to the unit.

Item	Symbol	Values		Unit	Remark
		Min.	Max.		
Operating voltage	VDD	-0.3	4.6	V	
	IOVCC	-0.3	4.6	V	
	VIN	-0.3	IOVCC+0.5	V	
	VO	-0.3	IOVCC+0.5	V	
Operation Temperature	TOP	-20	70	°C	
Storage Temperature	TST	-30	80	°C	

3.0 ELECTRICAL CHARACTERISTICS

Item	Symbol	Values			Unit	Remark
		Min.	Typ.	Max.		
Power voltage	VDD	2.4	2.75	3.3	V	
	IOVCC	1.65	1.8	3.3	V	
Input logic high voltage	VIH	0.8 IOVCC	-	IOVCC	V	
Input logic low voltage	VIL	VSS	-	0.2 IOVCC	V	

3.1 BACKLIGHT CHARACTERISTICS

Item	Symbol	Min	Typ	Max	Unit	Condition
Forward voltage	Vf	2.9	3.0	3.1	V	If = 40mA
Luminance	Lv	330	350	-	cd/m ²	If = 40mA
Number of LED	--	2			Piece	--



4.0 DIMENSIONAL DRAWING

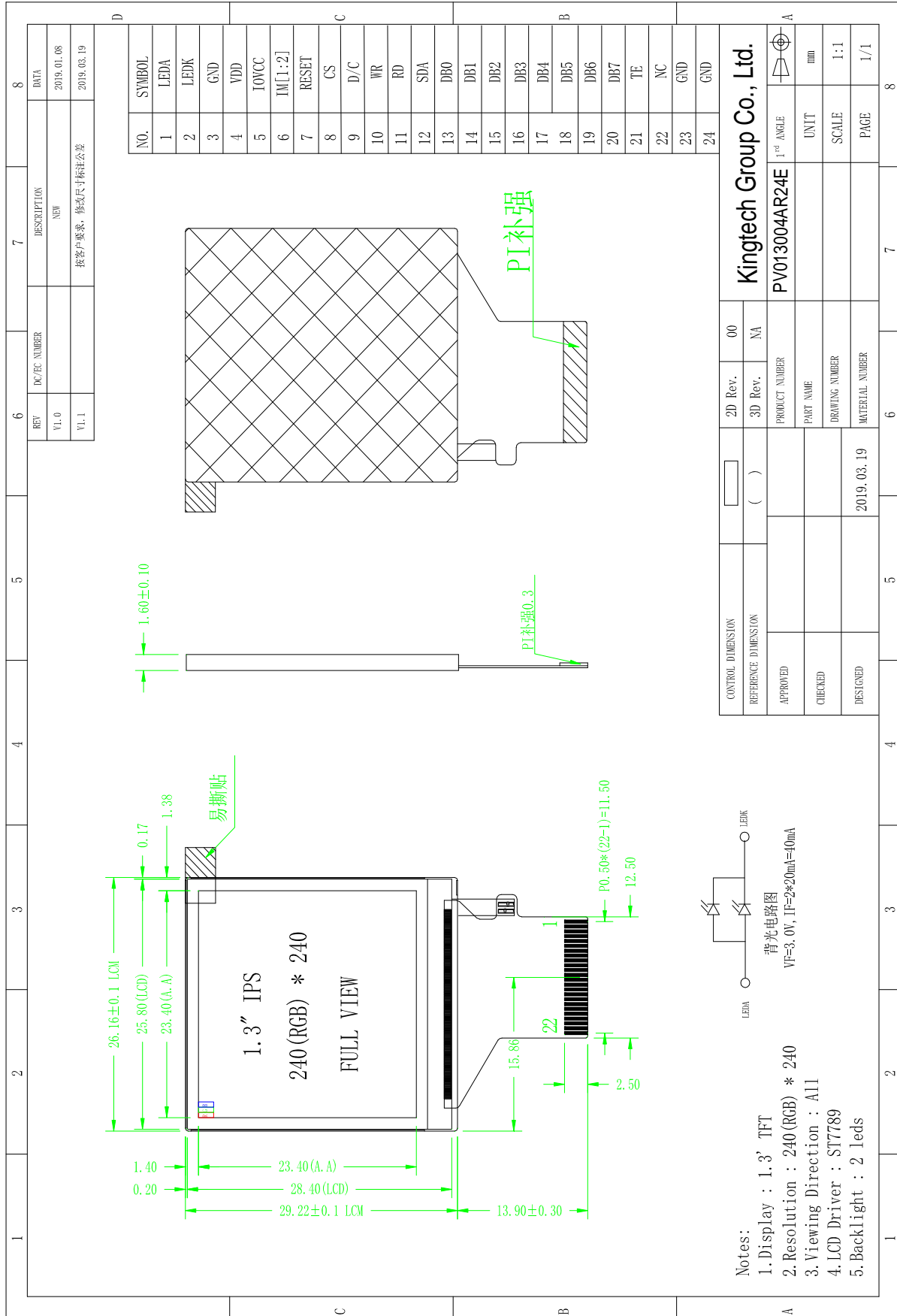



5.0 PINTERFACE PIN CONNECTIONS

Pin No.	Symbol	Function
1	LEDA	LED anode
2	LEDK	LED cathode
3	GND	Ground
4	VDD	Power Supply for Analog
5	IOVCC	Power Supply for I/O System
6	IM{1:2}	MCU interface mode select, 8bit parallel or SPI could be selected
7	RESET	Reset signal,active low
8	CS	Chip selection pin
9	D/C	Display data/command selection pin
10	WR	Write enable
11	RD	Read enable
12	SDA	SPI interface input/output pin
13	DB0	Data bus
14	DB1	Data bus
15	DB2	Data bus
16	DB3	Data bus
17	DB4	Data bus
18	DB5	Data bus
19	DB6	Data bus
20	DB7	Data bus
21	TE	Tearing effect signal
22	NC	No connection
23	GND	Ground
24	GND	Ground



6.0 TIMING CHARACTERISTICS OF INPUT SIGNAL

6.1AC Electrical Characteristics

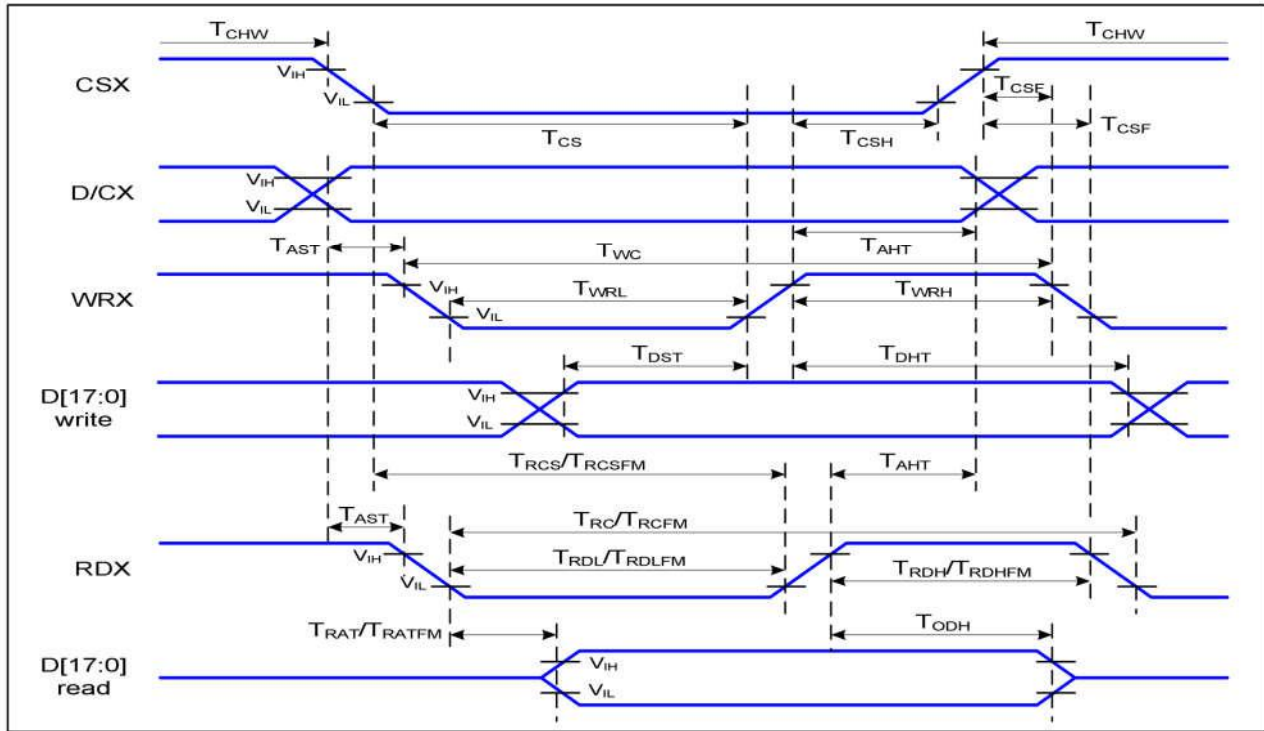

6.2 Timing Table

Signal	Symbol	Parameter	Min	Max	Unit	Description
D/CX	T_{AST}	Address setup time	0		ns	-
	T_{AHT}	Address hold time (Write/Read)	10		ns	
CSX	T_{CHW}	Chip select "H" pulse width	0		ns	-
	T_{CS}	Chip select setup time (Write)	15		ns	
	T_{RCS}	Chip select setup time (Read ID)	45		ns	
	T_{RCSFM}	Chip select setup time (Read FM)	355		ns	
	T_{CSF}	Chip select wait time (Write/Read)	10		ns	
	T_{CSH}	Chip select hold time	10		ns	
WRX	T_{WC}	Write cycle	66		ns	-
	T_{WRH}	Control pulse "H" duration	15		ns	
	T_{WRL}	Control pulse "L" duration	15		ns	
RDX (ID)	T_{RC}	Read cycle (ID)	160		ns	When read ID data
	T_{RDH}	Control pulse "H" duration (ID)	90		ns	
	T_{RDL}	Control pulse "L" duration (ID)	45		ns	
RDX (FM)	T_{RCFM}	Read cycle (FM)	450		ns	When read from frame memory
	T_{RDHFM}	Control pulse "H" duration (FM)	90		ns	
	T_{RDLM}	Control pulse "L" duration (FM)	355		ns	
D[17:0]	T_{DST}	Data setup time	10		ns	For CL=30pF



6.3 Reset timing

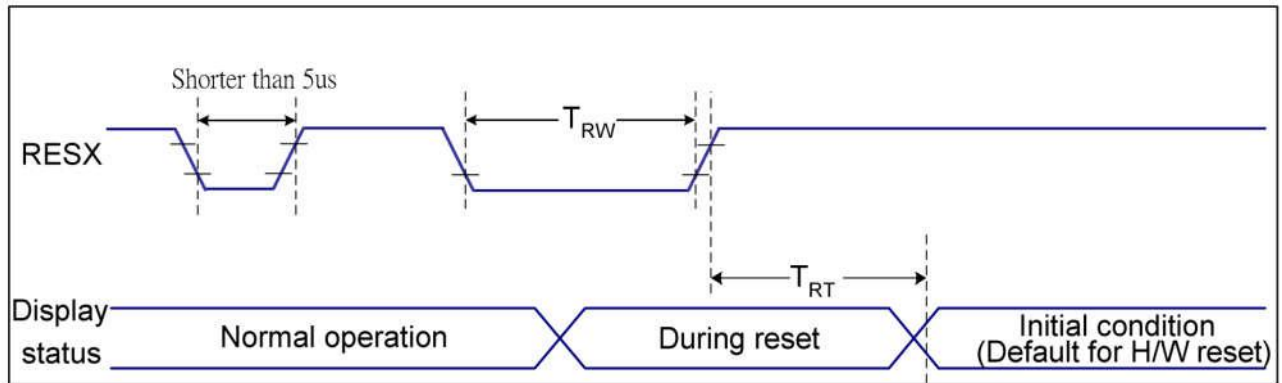

Related Pins	Symbol	Parameter	MIN	MAX	Unit
RESX	TRW	Reset pulse duration	10	-	us
	TRT	Reset cancel	-	5 (Note 1, 5)	ms
			120 (Note 1, 6, 7)	ms	



7.0 ELECTRO-OPTICAL CHARACTERISTICS

Ta=25°C

ITEM	SYMBOL	CONDITION	MIN.	TYP.	MAX.	UNIT	NOTE
Luminance	L	$\theta = 0^\circ$	330	350	--	cd/m ²	Note1
Luminance Uniformity	YU	13 Point	75	80	--	%	Note5
Contrast Ratio	CR	$\theta = 0^\circ$	--	800	--	-	Note3
Response Time	Rr+Tf	$\theta = 0^\circ$	--	25	--	ms	Note4
Viewing Angle K=Contrast Ratio>10	Horizontal	\ominus L	CR>10 $\theta = 0^\circ$	--	85	--	Note2
		\ominus R		--	85	--	
	Vertical	\ominus U		--	85	--	
		\ominus D		--	85	--	
Color Filter Chromaticity	White	X	$\theta = 0^\circ$	0.240	0.270	0.300	Note1
		Y		0.260	0.290	0.320	
	Red	X	$\theta = 0^\circ$	TBD	TBD	TBD	
		Y		TBD	TBD	TBD	
	Green	X	$\theta = 0^\circ$	TBD	TBD	TBD	
		Y		TBD	TBD	TBD	
	Blue	X	$\theta = 0^\circ$	TBD	TBD	TBD	
		Y		TBD	TBD	TBD	
Color gamut (NTSC ratio)			-	50	-	%	
Color Temperature			9010	10600	12190		

Test Conditions:

1. VDD=2.5V, the ambient temperature is 25°C.
2. The test systems refer to Note 2.



Note 1: Definition of viewing angle range

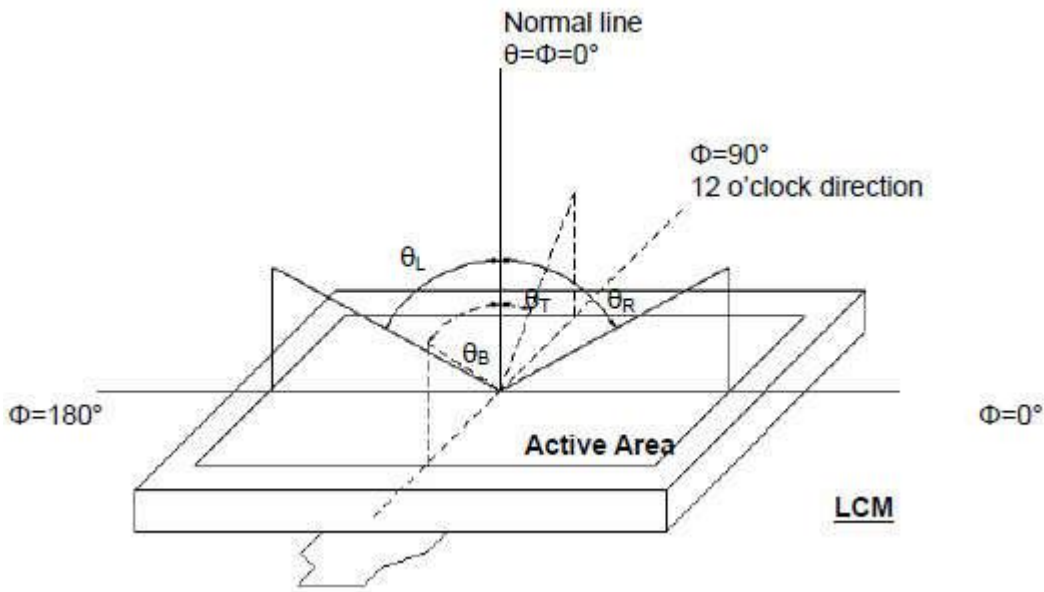

Fig. 4-1 Definition of viewing angle

Note 2: Definition of optical measurement system.

The optical characteristics should be measured in dark room. After 30 minutes operation, the optical properties are measured at the center point of the LCD screen. (Viewing angle is measured by ELDIM-EZ contrast/Height :1.2mm, Response time is measured by Photo detector TOPCON BM-7, other items are measured by BM-5A/ Field of view: 1° /Height: 500mm.)

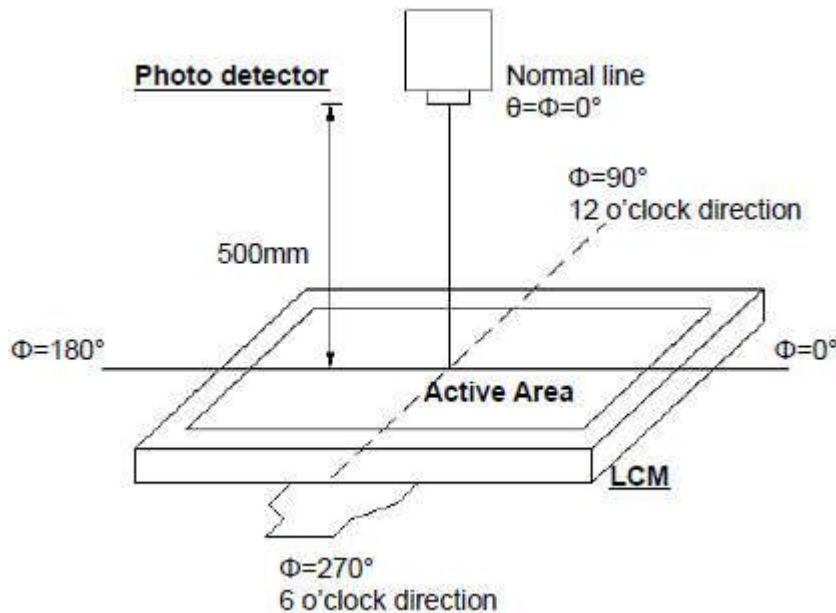

Fig. 4-2 Optical measurement system setup

Note 3: Definition of Response time

The response time is defined as the LCD optical switching time interval between



“White” state and “Black” state. Rise time (TON) is the time between photo detector output intensity changed from 90% to 10%. And fall time (TOFF) is the time between photo detector output intensity changed from 10% to 90%.

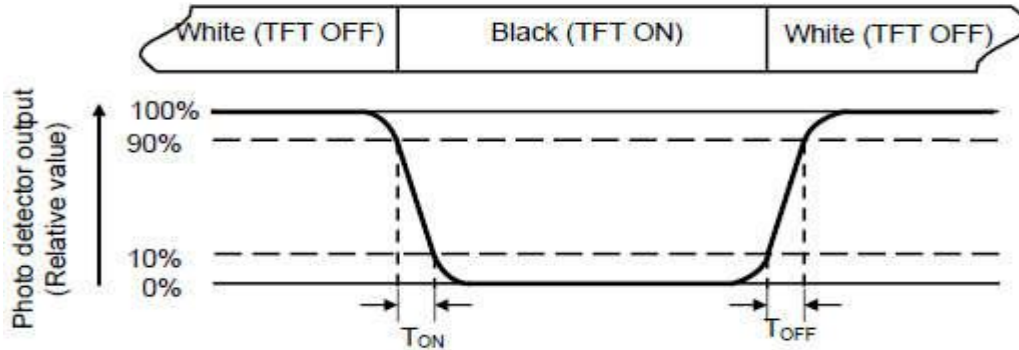

Fig. 4-3 Definition of response time

Note 4: Definition of contrast ratio

Luminance measured when LCD on the "Black" state

Luminance measured when LCD on the "White" state

Contrast ratio (CR) =

Note 5: Definition of color chromaticity (CIE1931)

Color coordinates measured at center point of LCD.

Note 6: All input terminals LCD panel must be ground while measuring the center area of the panel. The LED driving condition is IL=200mA .

Note 7: Definition of Luminance Uniformity

Measure the luminance of gray level 63 at 9 points

$$\delta W9p = \{ \text{Minimum} [L (1)+ L (6)+ L (7)+ L (8)+ L (9)+ L (10)+ L (11) +L (12) +L (13)] /$$

$$\text{Maximum} [L (1)+ L (6)+ L (7)+ L (8)+ L (9)+ L (10)+ L (11) +L (12) +L (13)] \} * 100\%$$

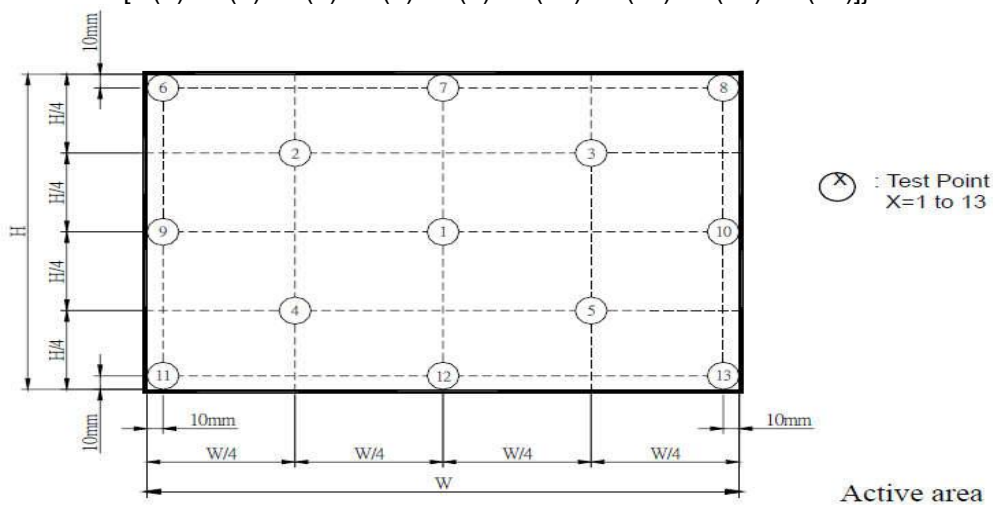



8.0 RELIABILITY

8.1 MTBF

The LCD module shall be designed to meet a minimum MTBF value of 50000 hours with normal. (25°C in the room without sunlight)

8.2 Tests

NO.	Test Item	Test condition	Criterion
1	High Temperature Storage	60°C±2°C 96H Restore 2H at 25°C Power off	
2	Low Temperature Storage	-10°C±2°C 96H Restore 2H at 25°C Power off	
3	High Temperature Operation	50°C±2°C 96H Restore 2H at 25°C Power on	
4	Low Temperature Operation	0°C±2°C 96H Restore 2H at 25°C Power on	
5	High Temperature & Humidity Operation	40°C±2°C 90%RH 96H Power on	
6	Temperature Cycle	-10°C ↔ 25°C ↔ 60°C 30min 5min 30min after 10cycle, Restore 2H at 25°C Power off	After testing, cosmetic and electrical defects should not happen.
7	Vibration Test	10Hz~45Hz, 100m/s ² , 120min	
8	Shock Test	Half-sinewave, 300m/s ² , 11ms	
9	Drop Test(package state)	800mm, concrete floor, 1corner, 3edges, 6 sides each time	1.After testing, cosmetic and electrical defects should not happen. 2.the product should remain at initial place 3.Product uncovered or package broken is not permitted.
10	Electro Static Discharge Test (non-operation)	150pF, 330Ω, Contact: ±4KV, Air: ±8KV Measure point :LCD glass and metal bezel 200pF, 0Ω, ±200V contact test Measure point :IF connector pins	IEC61000-4-2: 2001 GB/T17626.2-2006



9.0 INSPECTION STANDARDS

9.1 Purpose

This incoming inspection standard shall be applied to TFT-LCD supplied by Kingtech to its customer.

9.2 Scope

This inspection standard contains Cosmetic Specifications and Electrical Specifications.

9.3 Classification of defects

9.3.1 Major defect.

The major defect is a defect that is likely to result in product failure or reduction in Product's intended usage.

9.3.2 Minor defect.

The minor defect is a defect that has little bearing on the effective use or Operation of the product.

9.4 Definition

9.4.1 Display area definition

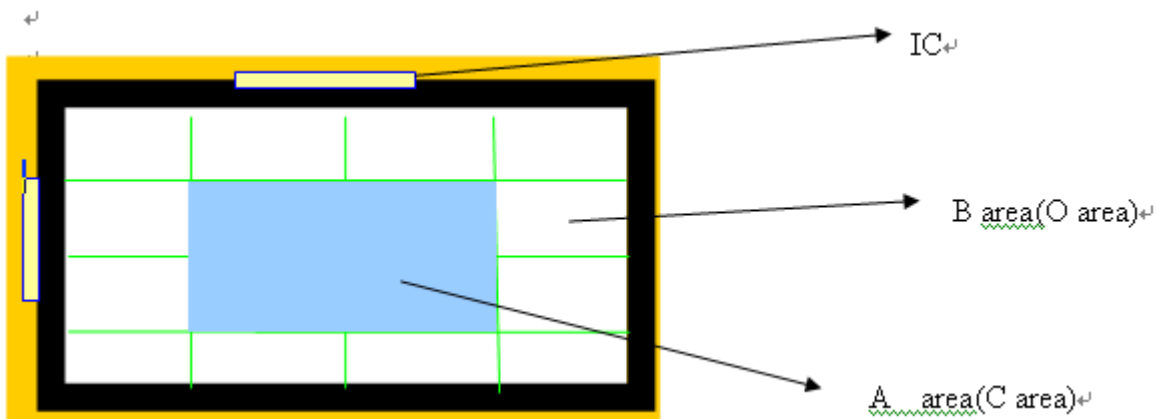



9.5 Inspection conditions is as follows

- 9.5.1 Viewing distance is approximately 35-40 cm
- 9.5.2 Viewing angle is normal to the LCD panel as 45°
- 9.5.3 Ambient temperature is approximately 25±5°C
- 9.5.4 Ambient humidity is 60±5% RH
- 9.5.5 Ambient luminance is from 300-500 Lux.
- 9.5.6 Input signal timing should be typical value(3s-5s).
- 9.5.7 Mura & Light leakage inspection at ND-Filter 6%.

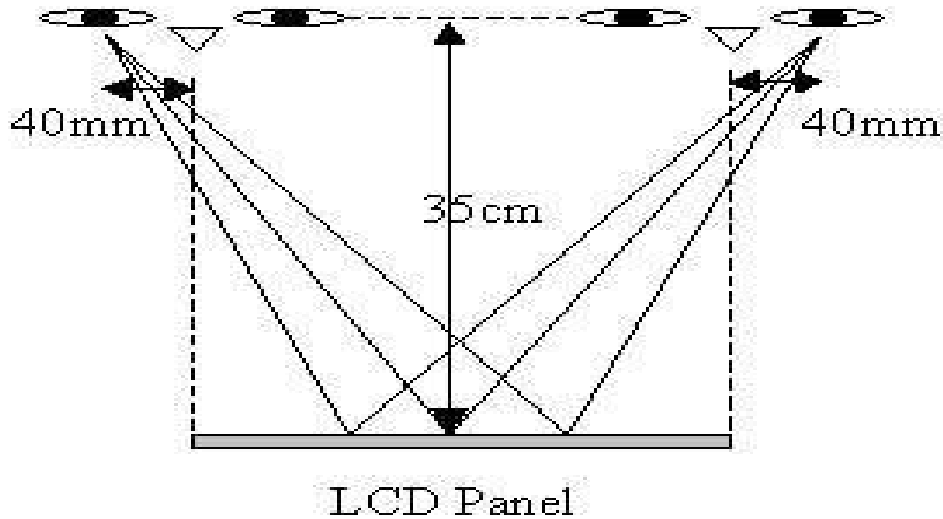
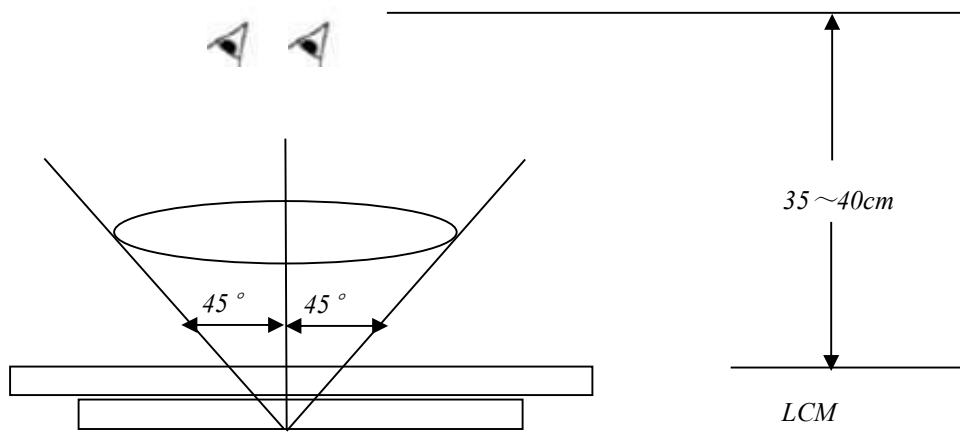



9.6 Sampling method

9.6.1 According to the MIL-STD-105E general inspection level , II Sampling plan.

9.6.2 AQL: MA 0.65 MI 1.0

9.7 Inspection Criteria

DEFECT TYPE		LIMIT		Defect	Note		
VISUAL DEFECT	SCRATCH		$W \leq 0.05\text{mm}$ and $L \leq 5\text{mm}$	Ignore	Maj	NOTE1	
			$0.05\text{mm} < W \leq 0.2\text{mm}$ $L \leq 10\text{mm}$	$N \leq 4$			
			$10\text{mm} < L, 0.1\text{mm} < W$	$N = 0$			
	INTERNAL	SPOT	$\Phi \leq 0.2\text{mm}$	Ignore			
			$0.2\text{mm} < \Phi \leq 0.5\text{mm}$	$N \leq 4$			
			$\Phi > 0.5\text{mm}$	$N = 0$			
		FIBER	$0.1\text{mm} \leq W \leq 0.2\text{mm}$ $L \leq 2.5\text{mm}$	$N \leq 4$			
			$0.2\text{mm} < W, 2.5\text{mm} < L$	$N = 0$			
		POLARIZER BUBBLE	$\Phi \leq 0.25\text{mm}$	Ignore			
			$0.25\text{mm} < \Phi \leq 0.5\text{mm}$	$N \leq 4$			
			$\Phi > 0.5\text{mm}$	$N = 0$			
		DENT	$\Phi < 0.25\text{mm}$	Ignore			
			$0.25\text{mm} \leq \Phi \leq 0.5\text{mm}$	$N \leq 4$			
			$\Phi > 0.5\text{mm}$	$N = 0$			
ELECTRICAL DEFECT	BRIGHT DOT		C Area	O Area	Total	Maj	NOTE2 NOTE3
			$N \leq 4$ (contain C area and O area)		$N \leq 4$		
	DARK DOT		$N \leq 5$ (contain C area and O area)		$N \leq 5$		
	TWO ADJACENT DOT		$N \leq 1$	$N \leq 2$	$N \leq 3$		
	THREE OR MORE ADJACENT DOT		NOT ALLOWED				
	LINE DEFECT		NOT ALLOWED				



Note1: Minimum distance between dot defects and spot is 5mm;

Note2: The definition of Bright dot and Dark dot

-bright area is more than 50% of one dot

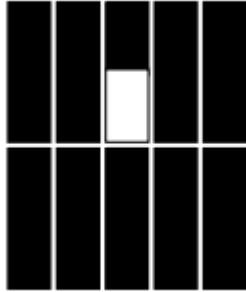

-dark area is more than 50% of one dot

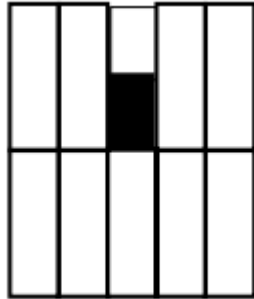

-The bright dot shall be visible under ND-Filter 5% as following:

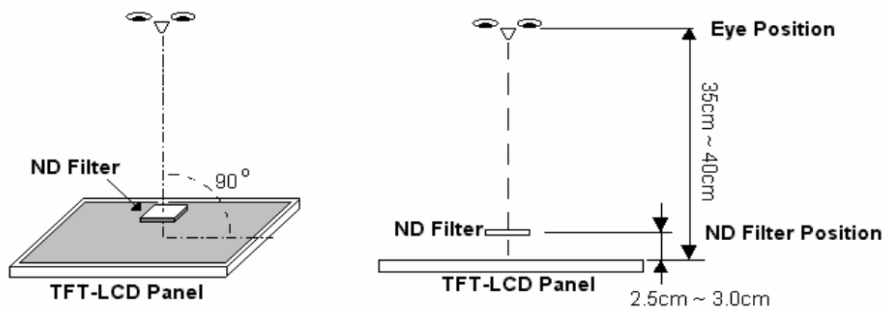

NOTE3:

- A bit rate(bright dot model) $\leq 10\%$;
- Class Chipping but not affect the function of quality OK;
- Polarizing film appearance does not affect the function OK;



10.0 HANDLING PRECAUTION

- (1) Don't disassemble and reassemble the module by self.
(禁止自行拆解)
- (2) Acid, alkali, alcohol or touched directly by hand will damage the display.
(酸性、碱性、酒精或手的直接接触将会损伤显示面)
- (3) Static electricity will damage the module. Please configure grounding device.
(静电会损伤模组，请装配接地设备)
- (4) The strong vibration, shock, twist or bend will cause material damage, even module broken.
(强烈的撞击、震动、扭转或弯曲将会造成原材损伤，甚至面板破裂)
- (5) It is easy to cause image sticking while displaying the same pattern for very long time.
(长期显示同一画面会造成影像残留)
- (6) The response time, brightness and performance will vary from different temperature.
(响应时间、亮度与均匀性会因温度而有所改变)